

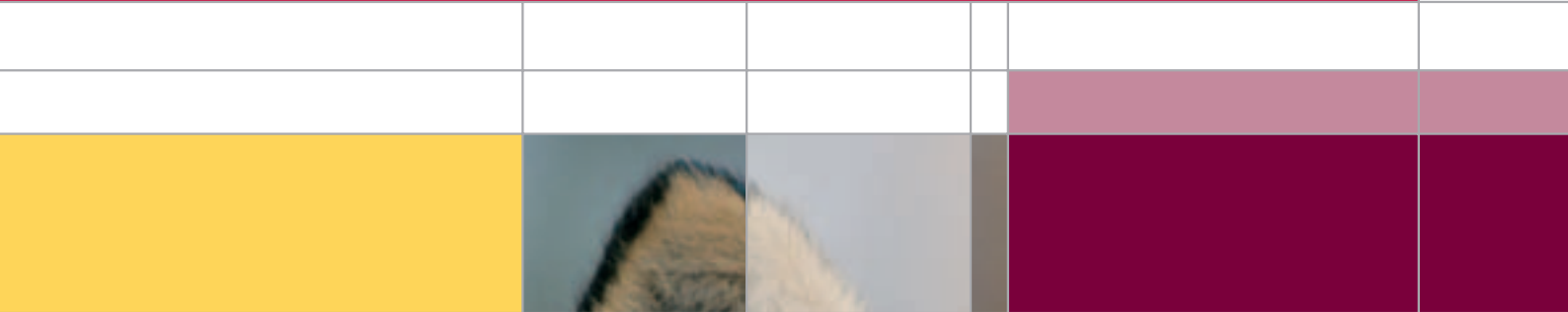

# Aluminium for mould and tool construction

Economical aspects of the use of aluminium for injection moulds				
---	--	--	--	--



# Aluminium for injection moulds



Aleris Rolled & Extruded Products - Europe, a division of Aleris International, Inc. (based in Beachwood, Ohio (U.S.A.)), is one of the world's leading suppliers of high quality aluminium products.

Annually more than 500,000 tons of semi-finished highly specialized and customized products for a wide variety of end users are manufactured and supplied worldwide using plants located in Koblenz, Bonn, Vogt and Bitterfeld (Germany), Duffel (Belgium) and Tianjin (China).

The prerequisites are state-of-the-art production plants, process- and product-oriented research and development, a comprehensive quality management system, sound marketing and distribution structures as well as healthy, safe and environmentally-friendly working conditions; success, however, is primarily based on highly skilled and motivated employees.

As a result of both experience and know-how, which have been gained by being the principal supplier to many industries, and continuous investment in the prerequisites, products have been improved continually to satisfy fully the requirements of the tool- and mould-making industry.

## The project "ALUMOPLA"

In February 2005 the European Union completed a project with the project acronym "ALUMOPLA", titled "Aluminium moulds for plastic processing industry".

The project description was as follows:

The mass production industry is confronted consumers with stringent requirements demanding products tailored to their needs with reduced costs and time-to-market. Moulds made of aluminium alloys, have successfully entered the market of plastic blow-moulding and the thermoforming. Because of insufficient mechanical properties, aluminium moulds, except as prototype or pre-series moulds, do not yet exist on the plastic injection market or for resin transfer moulding.

## The result was as follows:

Aluminium moulds, however, present remarkable properties compared to steel moulds:

1. At least 30% gain in machining time of the fabrication of the mould,
2. At least 30% gain in productivity since the thermal conductivity of aluminium is superior to that of steel,

3. Gain in quality of plastic injected parts since the cooling is more homogeneous,
4. Weight saving since the density of aluminium is three times lower to that of steel. This leads also to easy handling for large moulds.

## Solutions in aluminium

Based upon the project "ALUMOPLA", Aleris Rolled & Extruded Products - Europe, in cooperation with their specialized distributors, has analyzed the possibilities of the advanced use of aluminium for the plastic processing industry.

It is a fact that aluminium moulds are already established both as prototyping or pre-series moulds and for medium production runs of medium to large common plastic components used in the automotive, motorcycle, furniture, sport and household appliance markets.

The brochure "Aluminium for mould and tool construction: Economical aspects of the use of aluminium for injection moulds" gives a brief summary of the analysis and presents the properties and characteristics of GIANTAL, WELDURAL and HOKOTOL.

# Reduction of mould cost



## Total cost analysis

Three elements are used for the cost analysis of a plastic component:

- mould costs for the forecast number of pieces
- production costs of the press per hour  
+ material cost  
+ cost of rejected pieces
- working capital

## Production costs of plastic injected parts using aluminium in comparison to steel

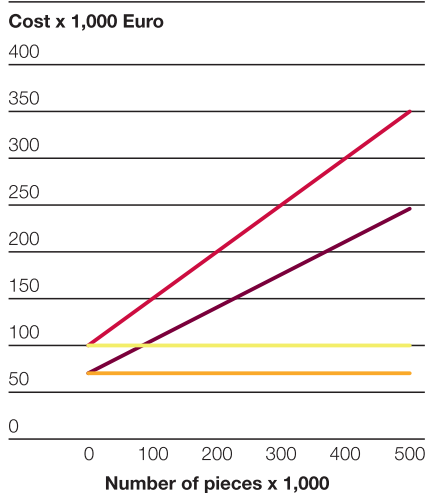

- Total costs steel
- Total costs aluminium
- Cost of steel mould
- Cost of aluminium mould

End-users can reduce the total production costs of their product by using aluminium moulds.

## Reduction of mould costs

The mould costs can be obtained by the sum of the following items:

- materials
- mould components (fittings, columns, heaters, hot chambers, ...)
- working capital
- machining (tools and lubricants/setup of machinery and mould, ...)

## Cost of materials

Although the density ratio of aluminium to steel is 1:3, it is necessary to use a greater thickness for aluminium alloys. Thus in reality the expected weight saving is approximately half of the weight of the original steel part.

In cases where aluminium alone is not able to fulfil the required mechanical properties, it is possible to use a composite mould made from aluminium and steel.

## Cost of mould components

- standard steel components can be used in conjunction with aluminium without problems
- most aluminium moulds have steel parts

Thus the cost of the components for both, aluminium and steel moulds, are equal.

## Working capital

Aluminium moulds are manufactured in less time therefore substantial financial advantages can be obtained.

## Cost of machining

The following machining time comparison table was constructed after taking into consideration the variability caused by different machine tools and tooling.

## Machining time (h)

Operation	Aluminium	Steel
Milling	1	5-10
Drilling	1	5
EDM	1	4
Polishing	1	3-4
Photo-engraving	1	4-5

# Examples for reduction of mould costs

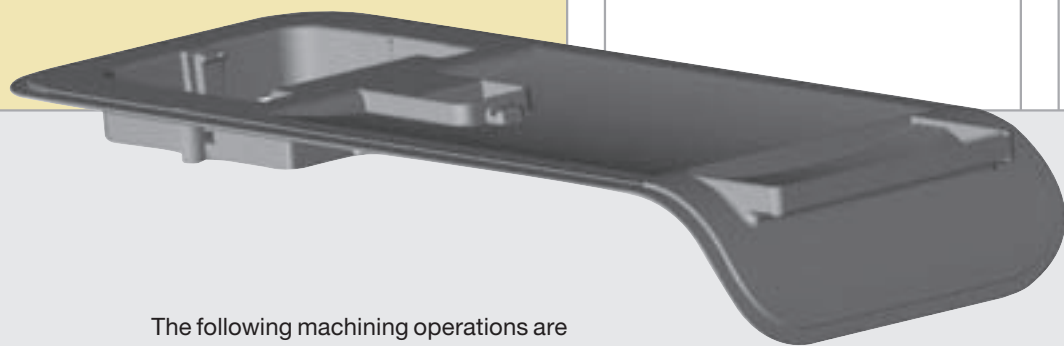
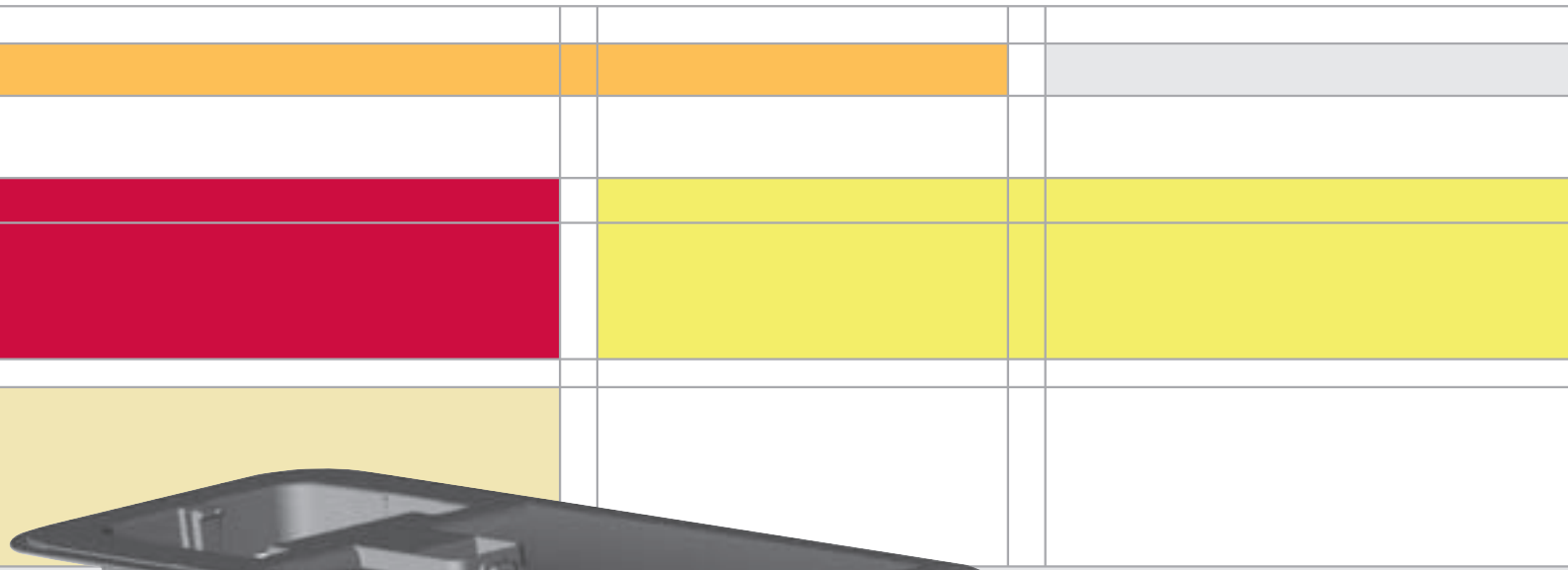

The following machining operations are possible without any problems:

- repair welding
- surface hardening (anodization, chemical coating (CVD), nickel coating, ...)

Additional advantages:

- ease of handling
- no need for continuous surveillance during machining
- approximately five times longer life-time of machining tools

**Saving of machining costs up to 35% can be obtained.**

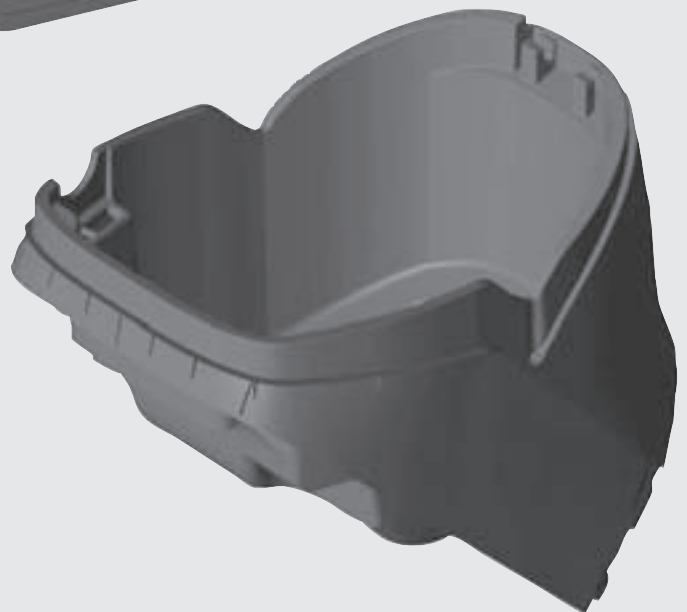

## Reduction of mould costs

	Front dial Washing machine	Under seat component Motorcycle	Door panel component Motorcar
Alloy	HOKOTOL	WELDURAL	WELDURAL
Surface	Mirror finish	Mill finish	Photo-engraved finish
Type of plastic	ABS	PP + 20% Talc	PP
Foreseen closures	300,000	40,000	100,000
<b>Advantage compared to Steel 1.2311</b>			
Cost	33%	25%	24%
Manufacturing time	3 weeks	2 weeks	2 weeks

Lightweight and cost efficient

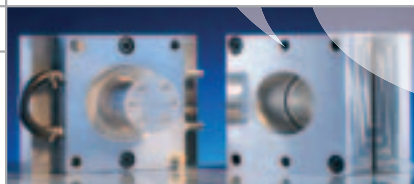

### Reduction of mould costs

	Flower stand	Swing arm
Weight/piece	0.022 kg (0.049 lbs)	0.055 kg (0.121 lbs)
Until now produced	700,000 pcs	1,000 pcs
Type of plastic	PP	PA6 + 30% GF
Method of production	Injection	Injection
Temperature of plastic injection	225°C (437°F)	235°C (455°F)
Mould temperature	25°C-30°C (77°F-86°F)	80°C (176°F)
Injection pressure	600 bar (8,700 psi)	800 bar (11,600 psi)
Mould material	Aluminium 7075 and Steel 37	Aluminium 7075 and Steel 37

### Savings/benefits of the use of an aluminium/steel composite mould in comparison to a steel mould

	Flower stand	Swing arm
Mould weight	- 42%	- 54%
Price of material	- 47%	- 50%
Mould machining cost	- 33%	- 24%
Production/min	+ 35%	+ 10%
Price/piece	- 33%	- 9%

# Cycle time of injection moulding



## Reduction of the moulding cycle

The cycle time during injection moulding is driven by three elements:

- pressure
- specific volume
- temperature

For semi-crystalline plastics (POM, PA, PE, PP, PBT, ...) and even more for the other (PS, ABS, PC, PPO, PMMA) the cycle reduction depends on a reduction of the cooling time.

Due to its higher thermal conductivity compared to steel it is possible to get cycle reduction of up to 50% by using aluminium moulds.

## Cycle time during injection moulding

■ Cooling time	70%
■ Injection time	5%
■ Holding pressure time	10%
■ Part ejection time	15%

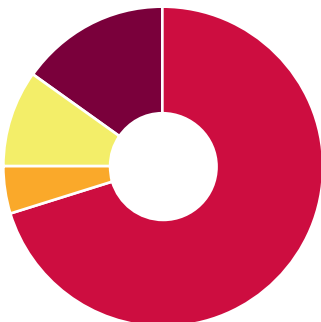

## Thermal conductivity of aluminium in comparison to steel

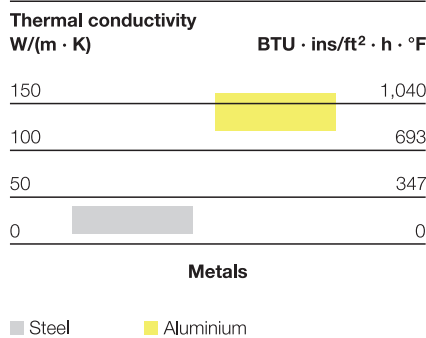

## Higher quality of the moulded pieces

- Optimal control of the temperature in the mould by using aluminium reduces residual stresses that can cause breakages. This is a plus for amorphous materials (PS, ABS, PC, PPO, PMMA).
- Temperature differences in the mould and/or different cooling speeds are the causes of deformations and twistings of the moulded pieces, especially for semi-crystalline plastics (POM, PA, PE, PP, PBT, ...). Aluminium reduces these differences.
- For semi-crystalline plastics (POM, PA, PE, PP, PBT, ...), it is not only a question of cooling speed, but the cooling must be optimized with regard to the type of polymer and the geometry of the piece (thickness). Use of aluminium grants uniformity of the temperature.

## Summary

### Major advantages of using aluminium moulds are:

- weight saving
- better machinability
- shorter cycle time

### It is also to be taken into consideration:

- reduction in time to market
- longer life time of the presses
- easier mould handling and stocking (often with forklifts instead of cranes)
- higher recovery if the mould is scrapped

The use of aluminium moulds improves quality aspects such as the level of internal stresses, distortion, porosity and dimensional tolerances.

Aleris Rolled & Extruded Products - Europe, via specialized distributors, offers a wide range of aluminium alloys for various injection moulding applications.

# Properties and characteristics of GIANTAL, WELDURAL and HOKOTOL

We would be pleased to supply you with any further information about our activities.

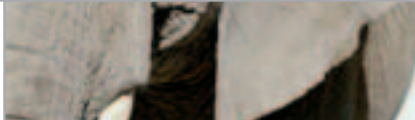

## The classic alloy: GIANTAL

GIANTAL is a highly developed form of 5083-O which used to be the alloy used in fabricating the first generation of aluminium tools. GIANTAL is distinguished by significantly low internal stresses, the property which lends itself to excellent form stability during the process of milling the plate. The uniformity of its properties is remarkable, even when the plate is extremely thick. In addition, it exhibits good weldability and corrosion resistance.

For a non-heat treatable alloy it maintains a relatively good strength, even at elevated temperatures. It is important to take into account that for many applications, this alloy might not have sufficient strength. It must also be noted that its freecutting characteristics are not as good as hard (heat treatable) alloys and this must be taken into consideration for machining operations. The wear resistance of GIANTAL is in general better than 5083.

## The universal alloy: WELDURAL

WELDURAL was introduced as a high quality material for the mould construction industry, designed for excellent weldability and high temperature resistance. Its strength is similar to that of medium to high strength aluminium alloys. WELDURAL matches 2017A and 7075 alloys not only in machinability, wear resistance, and capability of being polished, but it also offers other advantages.

This alloy permanently maintains its relatively high strength at temperatures up to 250°C (482°F). The weldability of WELDURAL is as good as that of alloy 5083. In comparison to alloy 7075, that typically demonstrates a drop in strength and higher plate thickness, WELDURAL maintains a relatively high strength with no significant dependence on plate thickness. This characteristic property of WELDURAL along with its low internal stress level, ensures excellent machinability and high dimensional stability.

## The high-strength alloy: HOKOTOL

Originally developed as a high-strength aluminium alloy for the aircraft industry, this alloy was further developed and optimized to satisfy the most demanding applications of the mould construction industry. The resulting mould construction alloy, HOKOTOL, exhibits very high strength and wear resistance as well as excellent uniformity of strength properties. These characteristics offer the mould builder an excellent machinability which remains constant across the entire thickness of the plate.

HOKOTOL plates are distinguished by their very high dimensional stability. Pertaining to surface porosity, they comply with the most demanding surface requirements.

High-strength aluminium alloys such as HOKOTOL are generally difficult to weld. However, repair welding is quite possible when an appropriate welding method such as MIG or TIG is used along with a suitable filler alloy. Due to higher strength imparted to aluminium alloys, they are now used for applications which were until recently reserved for low to medium strength steels.

## Characteristics of GIANTAL, WELDURAL and HOKOTOL

	Machinability	Uniformity	Dimension stability	Resistance to wear	Weldability	Polishability	Corrosion resistance
GIANTAL	Very good	Very good	Very good	Very good	Very good	Very good	Very good
WELDURAL	Very good	Very good	Very good	Very good	Very good	Very good	Very good
HOKOTOL	Very good	Very good	Very good	Very good	Very good	Very good	Very good

not suitable very good suitable

# www.aleris.com

## Aleris Rolled & Extruded Products - Europe

### “Marketing Communication”

#### Contact in Germany

Carl-Spaeter-Straße 10  
56070 Koblenz · Germany  
T +49 (0) 261 891 7329  
F +49 (0) 261 891 9 7329  
doreen.colausich@aleris.com  
www.aleris.com

#### Contact in Belgium

A. Stocletlaan 87  
2570 Duffel · Belgium  
T +32 (0) 15 30 27 24  
F +32 (0) 15 30 20 21  
ann.van.dessel@aleris.com  
www.aleris.com